



PCM1704

## *SoundPLUS*™ 24-Bit, 96kHz BiCMOS Sign-Magnitude DIGITAL-TO-ANALOG CONVERTER

### FEATURES

- SAMPLING FREQUENCY ( $f_s$ ): 16kHz to 96kHz
- 8X OVERSAMPLING AT 96kHz
- INPUT AUDIO DATA WORD: 20-, 24-Bit
- HIGH PERFORMANCE:
  - Dynamic Range: K Grade = 112dB typ
  - SNR: 120dB typ
  - THD+N: K Grade = 0.0008% typ
- FAST CURRENT OUTPUT:  $\pm 1.2\text{mA}/200\text{ns}$
- GLITCH-FREE OUTPUT
- PIN-PROGRAMMABLE DATA INVERSION
- POWER SUPPLY:  $\pm 5\text{V}$
- SMALL 20-LEAD SO PACKAGE

### DESCRIPTION

The PCM1704 is a precision, 24-bit digital-to-analog converter with exceptionally high dynamic performance. The ultra-low distortion and excellent low-level signal performance makes the PCM1704 an ideal candidate for high-end consumer and professional audio applications. When used with a digital interpolation filter, the PCM1704 supports 8X oversampling at 96kHz.

The PCM1704 incorporates a BiCMOS sign-magnitude architecture that eliminates glitches and other nonlinearities around bipolar zero. The PCM1704 is precision laser-trimmed at the factory to minimize differential linearity and gain errors.

In addition to high performance audio systems, the PCM1704 is well-suited to waveform synthesis applications requiring very low distortion and noise.

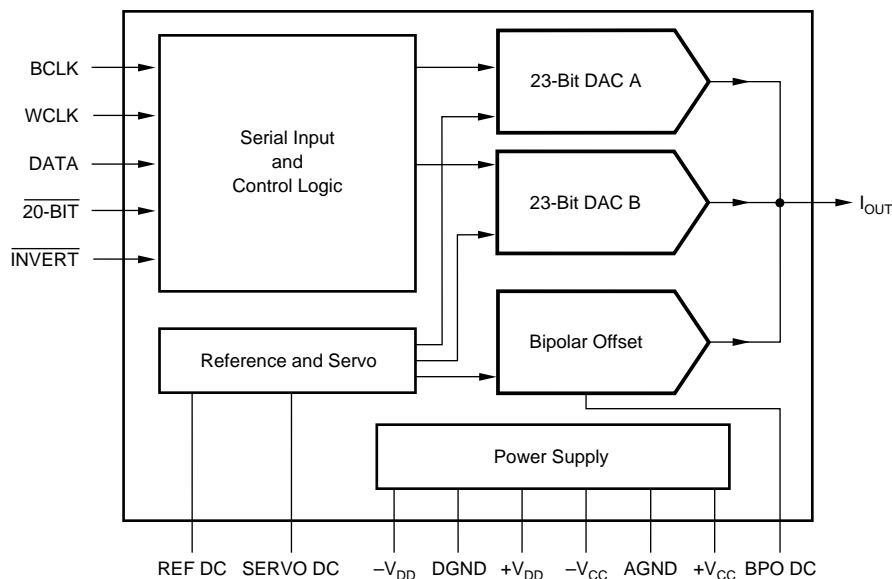

# SPECIFICATIONS

All specifications at  $T_A = +25^\circ\text{C}$ ,  $\pm V_{CC} = \pm V_{DD} = \pm 5\text{V}$ ,  $f_S = 768\text{kHz}$  ( $96\text{kHz} \cdot 8$ ), and 24-bit data, unless otherwise noted.

PARAMETER	CONDITIONS	PCM1704U			UNITS
		MIN	TYP	MAX	
<b>RESOLUTION</b>			24		Bits
<b>DATA FORMAT</b> Audio Data Interface Format Audio Data Code Sampling Frequency ( $f_S$ ) Input Clock Frequency			20-, 24-Bit, MSB-First Binary Two's Complement		
		16		96	kHz
				25	MHz
<b>DIGITAL INPUT/OUTPUT</b> Input Logic Level: $V_{IH}^{(1)}$ $V_{IL}^{(1)}$ $V_{IH}^{(2)}$ $V_{IL}^{(2)}$ Input Logic Current: $I_{IH}^{(1)}$ $I_{IL}^{(1)}$ $I_{IH}^{(2)}$ $I_{IL}^{(2)}$		+2.0 0 -3.0 -5.0		+5.0 +0.8 0 -4.2	V V V V
	$V_{IH} = +V_{DD}$ $V_{IL} = 0\text{V}$ $V_{IH} = 0\text{V}$ $V_{IL} = -V_{DD}$			$\pm 10$ $\pm 10$ $\pm 10$ -100	$\mu\text{A}$ $\mu\text{A}$ $\mu\text{A}$ $\mu\text{A}$
<b>DYNAMIC PERFORMANCE(3)</b> THD+N $V_O = 0\text{dB}$  $V_O = -20\text{dB}$  Dynamic Range  Signal-to-Noise Ratio Low Level Linearity	PCM1704U PCM1704U-J PCM1704U-K PCM1704U PCM1704U-J PCM1704U-K EIAJ, A-weighted PCM1704U, U-J PCM1704U-K EIAJ, A-weighted $f = 1002\text{Hz}$ at $-90\text{dB}$		0.0025 0.0015 0.0008 0.008 0.007 0.006  102 106 112	0.0030 0.0025 0.0015 0.020 0.015 0.01  110 112 120	% % % % % %  dB dB dB dB
<b>DC ACCURACY</b> Gain Error Bipolar Zero Error Gain Drift Bipolar Zero Error Drift	$0^\circ\text{C}$ to $70^\circ\text{C}$ $0^\circ\text{C}$ to $70^\circ\text{C}$		$\pm 1.0$ $\pm 0.5$ $\pm 25$ $\pm 5$	$\pm 3.0$ $\pm 1.0$	% of FSR % of FSR ppm of FSR/ $^\circ\text{C}$ ppm of FSR/ $^\circ\text{C}$
<b>ANALOG OUTPUT</b> Output Range Output Impedance Settling Time	$\pm 0.0003\%$ of FSR, $\pm 1.2\text{mA}$ Step		$\pm 1.2$ 1.0 200		mA k $\Omega$ ns
<b>POWER SUPPLY REQUIREMENTS</b> Voltage Range: $+V_{CC} = +V_{DD}$ $-V_{CC} = -V_{DD}$ Combined Supply Current: $+I_{CC}$ $-I_{CC}$	$+V_{CC} = +V_{DD} = +5.0\text{V}$ $-V_{CC} = -V_{DD} = -5.0\text{V}$	+4.75 -4.75	+5.0 -5.0 5 30	+5.25 -5.25 8 45	VDC VDC mA mA
<b>TEMPERATURE RANGE</b> Operation Storage		-25 -55		+85 +125	$^\circ\text{C}$ $^\circ\text{C}$

NOTES: (1) BCLK, WCLK, DATA. (2) 20BIT, INVERT. (3) Dynamic performance data is tested with 5534 I/V amp with 7.5k $\Omega$  feedback resistor. THD+N data is tested by Shibasaki 725C with 30kHz external LPF, 400Hz HPF, average mode. Input signal frequency = 1.1kHz.

## PIN CONFIGURATION

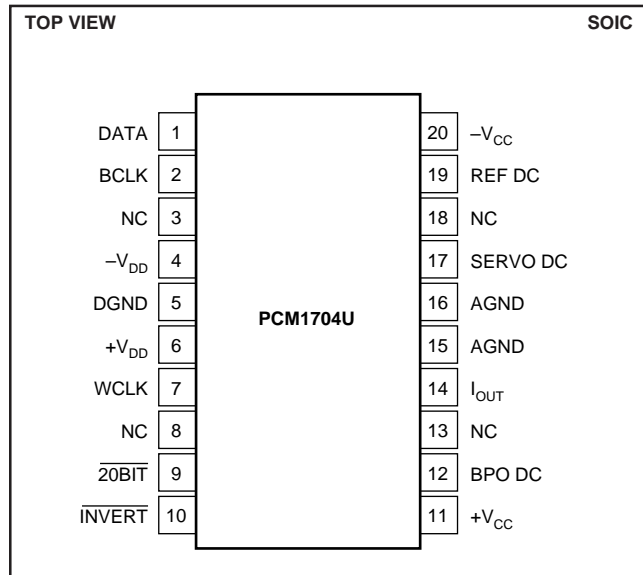

## PACKAGE INFORMATION

PRODUCT	PACKAGE	TEMPERATURE RANGE	PACKAGE DRAWING NUMBER <sup>(1)</sup>
PCM1704U	20-Lead SOIC	-25°C to +85°C	248

NOTE: (1) For detailed drawing and dimension table, please see end of data sheet, or Appendix C of Burr-Brown IC Data Book.

## ABSOLUTE MAXIMUM RATINGS

Supply Voltage, +V <sub>DD</sub> , +V <sub>CC</sub> .....	+6.5V
Supply Voltage Differences .....	±0.1V
GND Voltage Differences .....	±0.1V
Digital Input Voltage	
(BCLK, WCLK, DATA) .....	DGND -0.3V to (+V <sub>DD</sub> + 0.3V)
(20BIT, INVERT) .....	-V <sub>DD</sub> - 0.3V to (DGND + 0.3V)
Input Current (any pins except supply pins) .....	±10mA
Power Dissipation .....	300mW
Operating Temperature Range .....	-25°C to +85°C
Storage Temperature .....	-55°C to +125°C
Lead Temperature (soldering, 5s) .....	+260°C
Package Temperature (reflow, 10s) .....	+235°C

## PIN ASSIGNMENTS

PIN	NAME	I/O	FUNCTION
1	DATA	IN	Serial Audio Data Input.
2	BCLK	IN	Bit Clock Input for Serial Audio Data.
3	NC	—	No Connection.
4	-V <sub>DD</sub>	—	Digital Power, -5V.
5	DGND	—	Digital Ground.
6	+V <sub>DD</sub>	—	Digital Power, +5V.
7	WCLK	IN	Data Latch Enable Input.
8	NC	—	No Connection.
9	20BIT	IN	Input Data Word Selection <sup>(1)</sup> .
10	INVERT	IN	Input Data Polarity Selection <sup>(1)</sup> .
11	+V <sub>CC</sub>	—	Analog Power, +5V.
12	BPO DC	—	Bipolar Offset Decoupling Capacitor.
13	NC	—	No Connection.
14	I <sub>OUT</sub>	OUT	Current Output for Audio Signal.
15	AGND	—	Analog Ground.
16	AGND	—	Analog Ground.
17	SERVO DC	—	Servo Amplifier Decoupling Capacitor.
18	NC	—	No Connection.
19	REF DC	—	Band Gap Reference Decoupling Capacitor.
20	-V <sub>CC</sub>	—	Analog Power, -5V.

NOTE: (1) Internal pull-up resistors. Input level must be a voltage from -V<sub>DD</sub> to DGND.



## ELECTROSTATIC DISCHARGE SENSITIVITY

This integrated circuit can be damaged by ESD. Burr-Brown recommends that all integrated circuits be handled with appropriate precautions. Failure to observe proper handling and installation procedures can cause damage.

ESD damage can range from subtle performance degradation to complete device failure. Precision integrated circuits may be more susceptible to damage because very small parametric changes could cause the device not to meet its published specifications.

# SPECIFICATIONS

All specifications at +25°C,  $\pm V_{CC}$  and  $\pm V_{DD} = \pm 5.0V$ , unless otherwise noted.

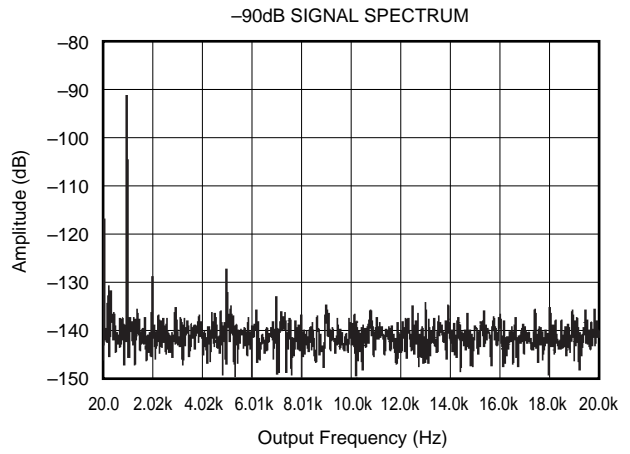
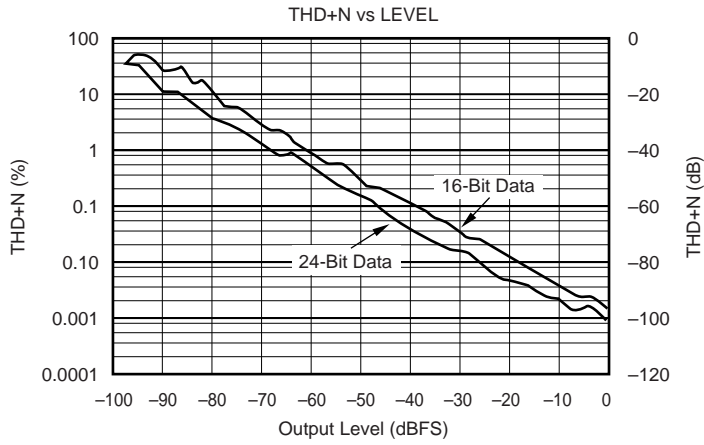

DAC OUTPUT  
-110dB, 24-Bit, 96kHz

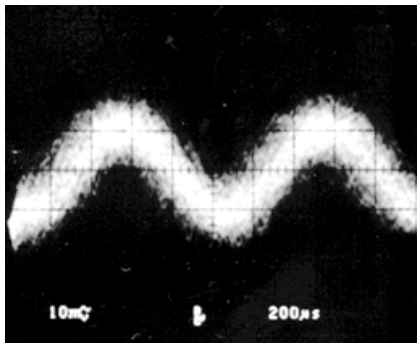

DAC OUTPUT  
-110dB, 20-Bit, 96kHz

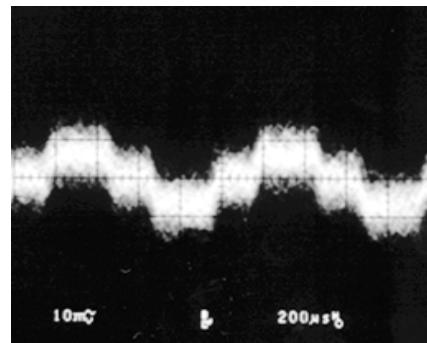

DAC OUTPUT  
-120dB, 24-Bit, 96kHz

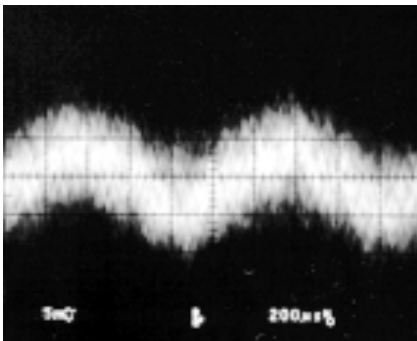

DAC OUTPUT  
-120dB, 20-Bit, 96kHz

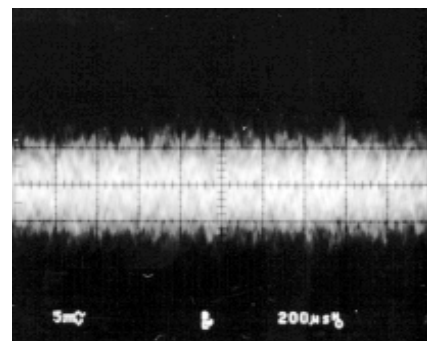

# SPECIFICATIONS (CONT)

All specifications at +25°C,  $\pm V_{CC}$  and  $\pm V_{DD} = \pm 5.0V$ , unless otherwise noted.

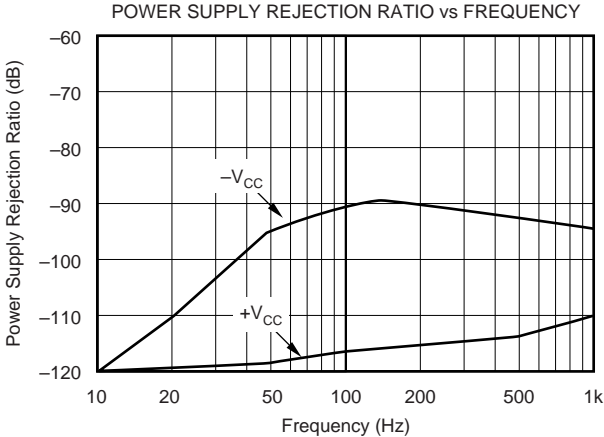

# THEORY OF OPERATION

## SIGN-MAGNITUDE ARCHITECTURE

Digital audio systems have traditionally used laser-trimmed, current-source DACs in order to achieve sufficient accuracy. However, even the best of these suffer from potential low-level nonlinearity due to errors in the major carry bipolar zero transition. Current systems have turned to oversampling data converters, such as the popular delta-sigma architectures, to correct the linearity problems. This is done, however, at the expense of signal-to-noise performance, and the noise shaping techniques utilized by these converters creates a considerable amount of out-of-band noise. If the outputs are not properly filtered, dynamic performance of the overall system will be adversely effected.

The PCM1704 employs an innovative architecture which combines the advantages of traditional DACs (e.g., excellent full-scale performance, high signal-to-noise ratio, and ease of use) with superior low-level performance. This architecture is referred to as sign-magnitude. Two DACs are combined in a complementary arrangement to produce an extremely linear output. The two DACs share a common reference, and a common R-2R ladder for bit current sources. The R-2R ladder utilizes dual balanced current segments to ensure ideal tracking under all conditions. By interleaving the individual bits of each DAC and employing precision laser-trimming of resistors, a highly accurate match between the two DACs is achieved.

The sign-magnitude architecture, which steps away from zero with small steps in both directions, avoids any glitching or large linearity errors, and provides an absolute current output. The low-level performance of the PCM1704 is such that true 24-bit resolution can be realized around the critical bipolar zero point.

## DISCUSSION OF KEY SPECIFICATIONS

### TOTAL HARMONIC DISTORTION + NOISE (THD+N)

This is the key specification for the PCM1704. Digital data words are read into the PCM1704 at eight times the standard DVD audio sampling frequency of 96kHz (e.g.,  $8 \times 96\text{kHz} = 768\text{kHz}$ ) to create a sinewave output of 1100Hz. The output of the DAC is then passed through analog signal conditioning circuitry before being input to a distortion analyzer.

For production testing, the output of the DAC is connected to a current-to-voltage (I/V) converter. The output of the I/V converter is then connected to a 40kHz, 3rd-order GIC low-pass filter. The filter output is then passed on to a programmable gain amplifier to provide gain for low-level test signals before being fed into an analog distortion analyzer (Shiba Soku Model 725 or equivalent).

For the audio bandwidth, the THD+N for the PCM1704 is essentially flat for all frequencies.

### DYNAMIC RANGE

Dynamic range in data converters is specified as the measure of THD+N at an effective output signal level of  $-60\text{dBFS}$  (conforms to EIAJ method with A-weighting applied). Resolution is commonly used as a theoretical measure of dynamic range, but it does not take into account the effects of distortion and noise at low signal levels. The sign-magnitude architecture of the PCM1704, with its ideal performance around bipolar zero, provides a more usable dynamic range (even with the strict audio definition) than any other previously available D/A converter.

### IDLE CHANNEL SIGNAL-TO-NOISE RATIO (SNR)

Another important specification for a digital audio converter is idle channel signal-to-noise ratio (Idle Channel SNR). This is the ratio of the noise on the DAC output at bipolar zero compared to the full-scale range of the D/A converter. To make this measurement, the digital input is continually fed the code for bipolar zero, while the output of the DAC is band limited from 20Hz to 20kHz and A-weighting is applied. The ideal channel SNR for the PCM1704 is typically greater than 120dB, making it ideal for low noise applications.

### OFFSET GAIN AND TEMPERATURE DRIFT

Although the PCM1704's primary application is in high performance digital audio systems where dynamic specifications are most important, specifications are also given for more traditional DC parameters. These include gain error, bipolar zero offset, temperature gain and offset drift. These specifications are important in test and measurement systems, which is the other main systems application for the PCM1704.

# AUDIO DATA INTERFACE

## BASIC OPERATION

The audio interface of the PCM1704 accepts TTL-compatible input levels. The data format at the DATA input of the PCM1704 is Binary Two's Complement, with the most significant bit (MSB) being first in the serial input bit stream. Table I shows the relationship between the audio input data and DAC output for the PCM1704. Any number of bits can precede the 24 bits to be loaded since only the last 24 bits will be transferred to the parallel DAC register after WCLK (pin 7) has gone LOW (logic 0).

BINARY TWO'S COMPLEMENT INPUT DATA (Hex)	DAC OUTPUT
7FFFFFFF	+ Full Scale
000000	Bipolar Zero
FFFFFFF	Bipolar Zero - 1 LSB
800000	- Full Scale

TABLE I. Digital Input/DAC Output Relationships.

Audio data is supplied to the DATA (pin 1) input. The bit clock is used to shift data into the PCM1704 and is supplied to BCLK (pin 2). All DAC serial input data bits are latched into the serial input register on the rising edge of BCLK. The serial-to-parallel data transfer to the DAC occurs on the falling edge of WCLK. The change in the output of the DAC occurs at the rising edge of the 2nd BCLK after the falling edge of WCLK. Figure 1 shows the audio data input format. Figure 2 shows the input timing relationships.

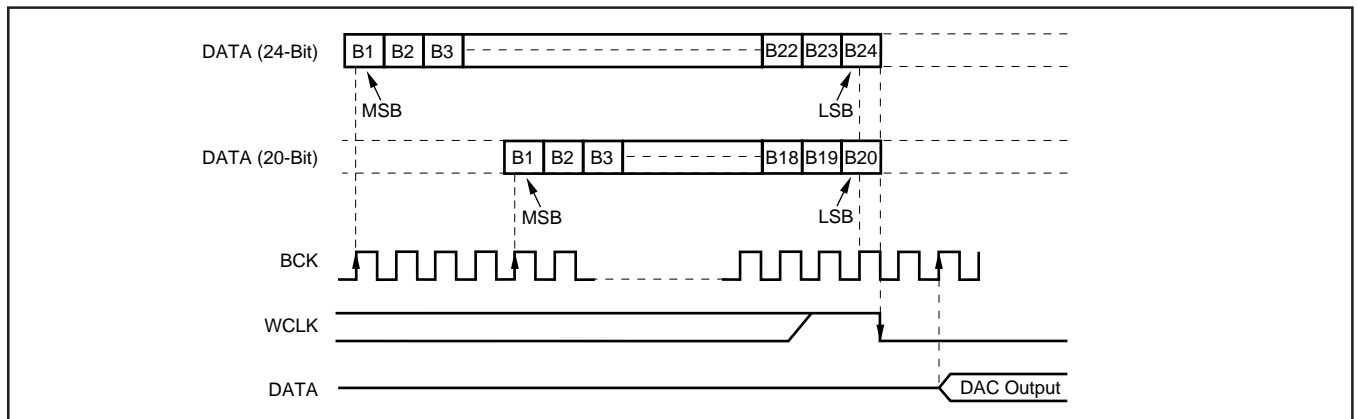

FIGURE 1. Audio Input Data Format.

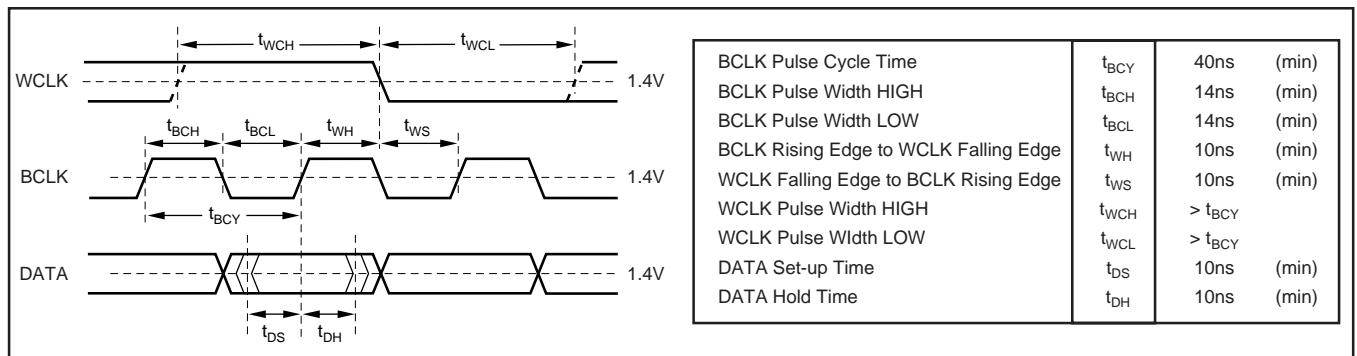

FIGURE 2. Audio Input Data Timing.

## Maximum Bit Clock (BCLK) Rate

The maximum BCLK rate is specified as 25MHz. This is derived from the 8X oversampling of the PCM1704. Given a 96kHz sampling rate, an 8X oversampling input and a 32-bit frame length, we get:

$$96\text{kHz} \cdot 8 \cdot 32 = 24.576\text{MHz}$$

## “Stopped Clock” Operation

The PCM1704 is normally operated with a continuous BCLK input. If BCLK is stopped between input data words, the last 24 bits shifted in are not actually transferred from the serial register to the parallel DAC register until WCLK goes LOW. WCLK must remain LOW until after the first BCLK cycle of the next data word to insure proper DAC operation. The specified setup and hold times for DATA and WCLK must be observed.

## DATA FORMAT CONTROL

Data format is controlled by two pins on the PCM1704—the  $\overline{20BIT}$  and  $\overline{INVERT}$  inputs. Their functions are described in the following paragraphs and tables.

### Input Word Length

$\overline{20BIT}$  (pin 9) is used to select the input data length. Table II shows the available selections. Pin 9 is internally pulled up to DGND and therefore, defaults to 24-bit data.

$\overline{20BIT}$ (Pin 9)	DATA WORD LENGTH
$\overline{20BIT} = H$ (DGND)	24-Bit Data Word
$\overline{20BIT} = L$ ( $-V_{DD}$ )	20-Bit Data Word

TABLE II. Input Word Length Selection.

## Input Data Inversion

$\overline{\text{INVERT}}$  (pin 10) is used to select the phase of the input data presented to the DAC. Table III shows the two options. Pin 10 is internally pulled up to DGND, and therefore defaults to normal, or non-inverting data.

$\overline{\text{INVERT}}$ (Pin 10)	PHASE
$\overline{\text{INVERT}} = \text{H (DGND)}$	Normal (non-inverted)
$\overline{\text{INVERT}} = \text{L (-V}_{\text{DD}})$	Inverted

TABLE III. Input Data Phase Selection.

# APPLICATIONS INFORMATION

## POWER SUPPLIES

For this discussion, please refer to the internal connection diagram for the PCM1704 in Figure 3. The PCM1704 only requires a  $\pm 5\text{V}$  supply for operation. Both positive supplies ( $+V_{\text{DD}}$  and  $+V_{\text{CC}}$ ) should be tied together at a single point and connected to a single  $+5\text{V}$  analog power supply. Similarly, both negative supplies ( $-V_{\text{DD}}$  and  $-V_{\text{CC}}$ ) should be tied at a single point and connected to a single  $-5\text{V}$  analog power

supply. No advantage is gained by using separate analog and digital power supplies. It is more important that the analog supplies used to drive these pins are as noise and ripple free as possible to reduce coupling of supply noise to the output.

Power supply decoupling capacitors should be used at each supply pin to maximize power supply rejection, as shown in Figure 3. All ground pins (AGND and DGND) should be connected to an analog ground plane as close to the PCM1704 as possible. The PCM1704 should reside entirely over the analog ground plane of the printed circuit board.

## Bypass and Decoupling Capacitor Requirements

Various-sized decoupling capacitors can be used, with no special tolerances being required. Figure 5 shows typical values used by Burr-Brown on our evaluation fixture, which designers can use as recommended values. All capacitors should be located as close to the appropriate pins of the PCM1704 as possible to reduce noise pickup from surrounding circuitry. Aluminum electrolytic capacitors are recommended for larger values, while metal-film or monolithic ceramic capacitors are used for smaller values.

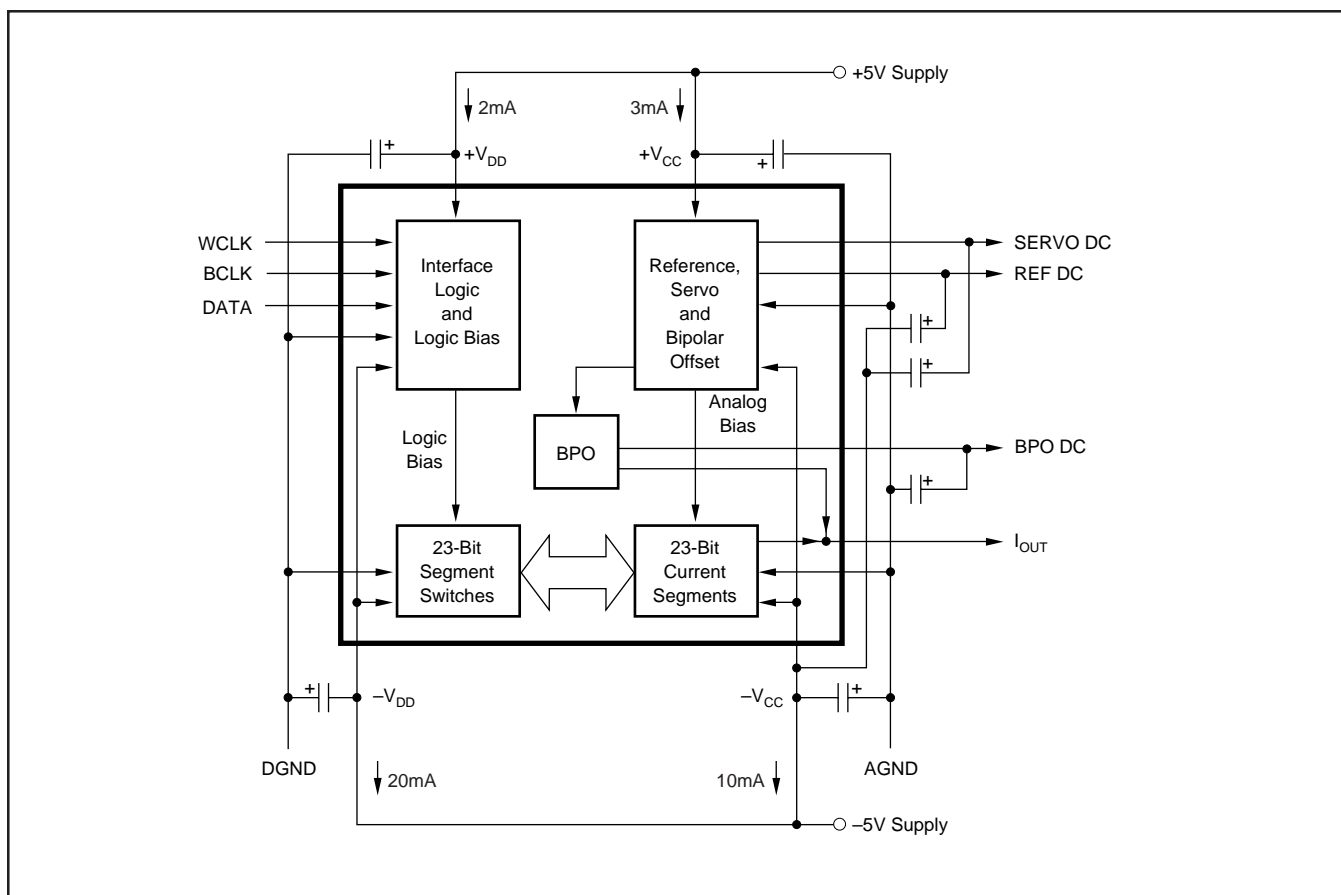

FIGURE 3. PCM1704 Internal Connection Diagram.



# TYPICAL APPLICATION EXAMPLES

The audio interface connections for a stereo audio application is shown in Figure 4. The audio data is input to the digital filter, which then oversamples the data by a factor of 8. The audio data is then filtered digitally and output to the PCM1704 DACs.

Figure 5 shows single channel circuit connections for a typical PCM1704 application. It shows the PCM1704 interface to the digital filter, the I/V converter, and the DAC post filter. Selection of an appropriate op amp for the I/V converter is critical for obtaining optimum dynamic performance from the PCM1704. The OPA627 is recommended for this application. Op amps with similar characteristics and faster settling times may also be used.

The suggested DAC post filter is a second-order lowpass active filter, using the multiple feedback (MFB) circuit technique. The OPA2134 is an excellent choice for the op amp in this circuit, since it is designed for high performance audio applications. The post filter is used to reconstruct and band limit the DAC output signal.

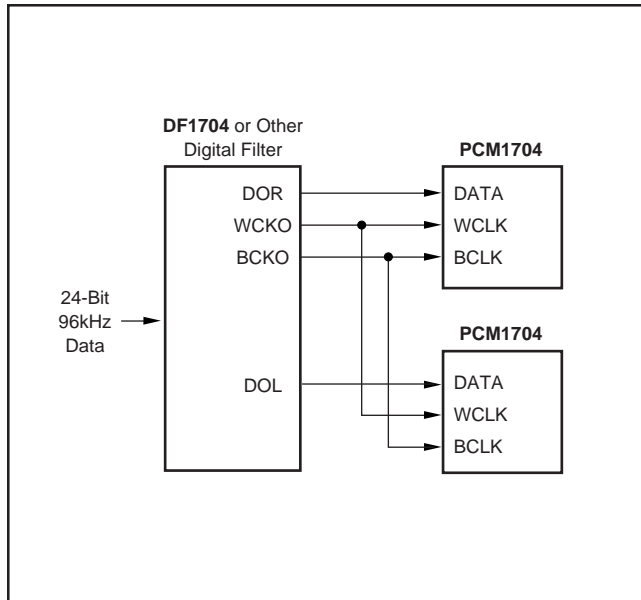

FIGURE 4. Audio Interface Connections for Stereo Audio Application.

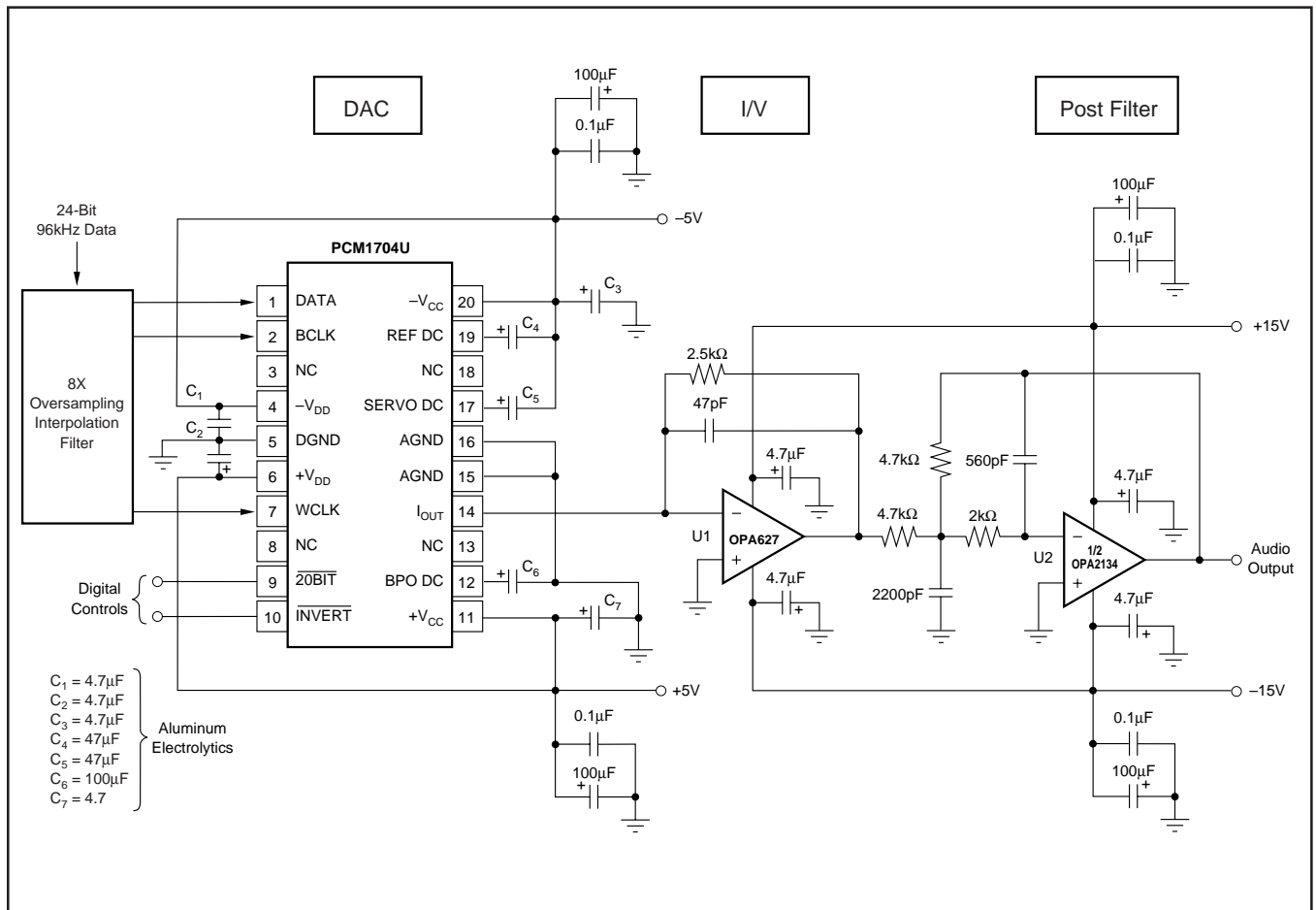

FIGURE 5. Typical Application Circuit (one channel shown).

**PACKAGING INFORMATION**

Orderable Device	Status <sup>(1)</sup>	Package Type	Package Drawing	Pins	Package Qty	Eco Plan <sup>(2)</sup>	Lead/ Ball Finish	MSL Peak Temp <sup>(3)</sup>	Samples (Requires Login)
PCM1704U	NRND	SO	NS	20	38	Pb-Free (RoHS)	CU SNBI	Level-2-260C-1 YEAR	
PCM1704U-J	NRND	SO	NS	20	38	Pb-Free (RoHS)	CU SNBI	Level-2-260C-1 YEAR	
PCM1704U-K	NRND	SO	NS	20	38	Pb-Free (RoHS)	CU SNBI	Level-2-260C-1 YEAR	
PCM1704U-K/2K	NRND	SO	NS	20	2000	Pb-Free (RoHS)	CU SNBI	Level-2-260C-1 YEAR	
PCM1704U/2K	NRND	SO	NS	20	2000	Pb-Free (RoHS)	CU SNBI	Level-2-260C-1 YEAR	

<sup>(1)</sup> The marketing status values are defined as follows:

**ACTIVE:** Product device recommended for new designs.

**LIFEBUY:** TI has announced that the device will be discontinued, and a lifetime-buy period is in effect.

**NRND:** Not recommended for new designs. Device is in production to support existing customers, but TI does not recommend using this part in a new design.

**PREVIEW:** Device has been announced but is not in production. Samples may or may not be available.

**OBSELETE:** TI has discontinued the production of the device.

<sup>(2)</sup> Eco Plan - The planned eco-friendly classification: Pb-Free (RoHS), Pb-Free (RoHS Exempt), or Green (RoHS & no Sb/Br) - please check <http://www.ti.com/productcontent> for the latest availability information and additional product content details.

**TBD:** The Pb-Free/Green conversion plan has not been defined.

**Pb-Free (RoHS):** TI's terms "Lead-Free" or "Pb-Free" mean semiconductor products that are compatible with the current RoHS requirements for all 6 substances, including the requirement that lead not exceed 0.1% by weight in homogeneous materials. Where designed to be soldered at high temperatures, TI Pb-Free products are suitable for use in specified lead-free processes.

**Pb-Free (RoHS Exempt):** This component has a RoHS exemption for either 1) lead-based flip-chip solder bumps used between the die and package, or 2) lead-based die adhesive used between the die and leadframe. The component is otherwise considered Pb-Free (RoHS compatible) as defined above.

**Green (RoHS & no Sb/Br):** TI defines "Green" to mean Pb-Free (RoHS compatible), and free of Bromine (Br) and Antimony (Sb) based flame retardants (Br or Sb do not exceed 0.1% by weight in homogeneous material)

<sup>(3)</sup> MSL, Peak Temp. -- The Moisture Sensitivity Level rating according to the JEDEC industry standard classifications, and peak solder temperature.

**Important Information and Disclaimer:** The information provided on this page represents TI's knowledge and belief as of the date that it is provided. TI bases its knowledge and belief on information provided by third parties, and makes no representation or warranty as to the accuracy of such information. Efforts are underway to better integrate information from third parties. TI has taken and continues to take reasonable steps to provide representative and accurate information but may not have conducted destructive testing or chemical analysis on incoming materials and chemicals. TI and TI suppliers consider certain information to be proprietary, and thus CAS numbers and other limited information may not be available for release.

In no event shall TI's liability arising out of such information exceed the total purchase price of the TI part(s) at issue in this document sold by TI to Customer on an annual basis.

**TAPE AND REEL INFORMATION**
**REEL DIMENSIONS**

**TAPE DIMENSIONS**

A0	Dimension designed to accommodate the component width
B0	Dimension designed to accommodate the component length
K0	Dimension designed to accommodate the component thickness
W	Overall width of the carrier tape
P1	Pitch between successive cavity centers

**TAPE AND REEL INFORMATION**

\*All dimensions are nominal

Device	Package Type	Package Drawing	Pins	SPQ	Reel Diameter (mm)	Reel Width W1 (mm)	A0 (mm)	B0 (mm)	K0 (mm)	P1 (mm)	W (mm)	Pin1 Quadrant
PCM1704U-K/2K	SO	NS	20	2000	330.0	25.4	8.8	13.1	2.8	12.0	24.0	Q1

TAPE AND REEL BOX DIMENSIONS



\*All dimensions are nominal

Device	Package Type	Package Drawing	Pins	SPQ	Length (mm)	Width (mm)	Height (mm)
PCM1704U-K/2K	SO	NS	20	2000	367.0	367.0	45.0

## IMPORTANT NOTICE

Texas Instruments Incorporated and its subsidiaries (TI) reserve the right to make corrections, enhancements, improvements and other changes to its semiconductor products and services per JESD46C and to discontinue any product or service per JESD48B. Buyers should obtain the latest relevant information before placing orders and should verify that such information is current and complete. All semiconductor products (also referred to herein as "components") are sold subject to TI's terms and conditions of sale supplied at the time of order acknowledgment.

TI warrants performance of its components to the specifications applicable at the time of sale, in accordance with the warranty in TI's terms and conditions of sale of semiconductor products. Testing and other quality control techniques are used to the extent TI deems necessary to support this warranty. Except where mandated by applicable law, testing of all parameters of each component is not necessarily performed.

TI assumes no liability for applications assistance or the design of Buyers' products. Buyers are responsible for their products and applications using TI components. To minimize the risks associated with Buyers' products and applications, Buyers should provide adequate design and operating safeguards.

TI does not warrant or represent that any license, either express or implied, is granted under any patent right, copyright, mask work right, or other intellectual property right relating to any combination, machine, or process in which TI components or services are used. Information published by TI regarding third-party products or services does not constitute a license to use such products or services or a warranty or endorsement thereof. Use of such information may require a license from a third party under the patents or other intellectual property of the third party, or a license from TI under the patents or other intellectual property of TI.

Reproduction of significant portions of TI information in TI data books or data sheets is permissible only if reproduction is without alteration and is accompanied by all associated warranties, conditions, limitations, and notices. TI is not responsible or liable for such altered documentation. Information of third parties may be subject to additional restrictions.

Resale of TI components or services with statements different from or beyond the parameters stated by TI for that component or service voids all express and any implied warranties for the associated TI component or service and is an unfair and deceptive business practice. TI is not responsible or liable for any such statements.

Buyer acknowledges and agrees that it is solely responsible for compliance with all legal, regulatory and safety-related requirements concerning its products, and any use of TI components in its applications, notwithstanding any applications-related information or support that may be provided by TI. Buyer represents and agrees that it has all the necessary expertise to create and implement safeguards which anticipate dangerous consequences of failures, monitor failures and their consequences, lessen the likelihood of failures that might cause harm and take appropriate remedial actions. Buyer will fully indemnify TI and its representatives against any damages arising out of the use of any TI components in safety-critical applications.

In some cases, TI components may be promoted specifically to facilitate safety-related applications. With such components, TI's goal is to help enable customers to design and create their own end-product solutions that meet applicable functional safety standards and requirements. Nonetheless, such components are subject to these terms.

No TI components are authorized for use in FDA Class III (or similar life-critical medical equipment) unless authorized officers of the parties have executed a special agreement specifically governing such use.

Only those TI components which TI has specifically designated as military grade or "enhanced plastic" are designed and intended for use in military/aerospace applications or environments. Buyer acknowledges and agrees that any military or aerospace use of TI components which have **not** been so designated is solely at the Buyer's risk, and that Buyer is solely responsible for compliance with all legal and regulatory requirements in connection with such use.

TI has specifically designated certain components which meet ISO/TS16949 requirements, mainly for automotive use. Components which have not been so designated are neither designed nor intended for automotive use; and TI will not be responsible for any failure of such components to meet such requirements.

### Products

Audio	<a href="http://www.ti.com/audio">www.ti.com/audio</a>
Amplifiers	<a href="http://amplifier.ti.com">amplifier.ti.com</a>
Data Converters	<a href="http://dataconverter.ti.com">dataconverter.ti.com</a>
DLP® Products	<a href="http://www.dlp.com">www.dlp.com</a>
DSP	<a href="http://dsp.ti.com">dsp.ti.com</a>
Clocks and Timers	<a href="http://www.ti.com/clocks">www.ti.com/clocks</a>
Interface	<a href="http://interface.ti.com">interface.ti.com</a>
Logic	<a href="http://logic.ti.com">logic.ti.com</a>
Power Mgmt	<a href="http://power.ti.com">power.ti.com</a>
Microcontrollers	<a href="http://microcontroller.ti.com">microcontroller.ti.com</a>
RFID	<a href="http://www.ti-rfid.com">www.ti-rfid.com</a>
OMAP Mobile Processors	<a href="http://www.ti.com/omap">www.ti.com/omap</a>
Wireless Connectivity	<a href="http://www.ti.com/wirelessconnectivity">www.ti.com/wirelessconnectivity</a>

### Applications

Automotive and Transportation	<a href="http://www.ti.com/automotive">www.ti.com/automotive</a>
Communications and Telecom	<a href="http://www.ti.com/communications">www.ti.com/communications</a>
Computers and Peripherals	<a href="http://www.ti.com/computers">www.ti.com/computers</a>
Consumer Electronics	<a href="http://www.ti.com/consumer-apps">www.ti.com/consumer-apps</a>
Energy and Lighting	<a href="http://www.ti.com/energy">www.ti.com/energy</a>
Industrial	<a href="http://www.ti.com/industrial">www.ti.com/industrial</a>
Medical	<a href="http://www.ti.com/medical">www.ti.com/medical</a>
Security	<a href="http://www.ti.com/security">www.ti.com/security</a>
Space, Avionics and Defense	<a href="http://www.ti.com/space-avionics-defense">www.ti.com/space-avionics-defense</a>
Video and Imaging	<a href="http://www.ti.com/video">www.ti.com/video</a>

**TI E2E Community** [e2e.ti.com](http://e2e.ti.com)